

Every successful building needs a strong foundation.

Trane® Foundation™ light-commercial rooftop units

It's the HVAC solution that delivers what you really want: simplicity in design, reliable performance, solid value, easy installation — and quick shipping, too.

Simple design and proven performance from durable, reliable, field-tested components.

Designed with input from rooftop owners and users to ensure we deliver the features you need and want.

Fast shipping: Many units ship the same day they're ordered, thanks to actively managed manufacturing and inventory.

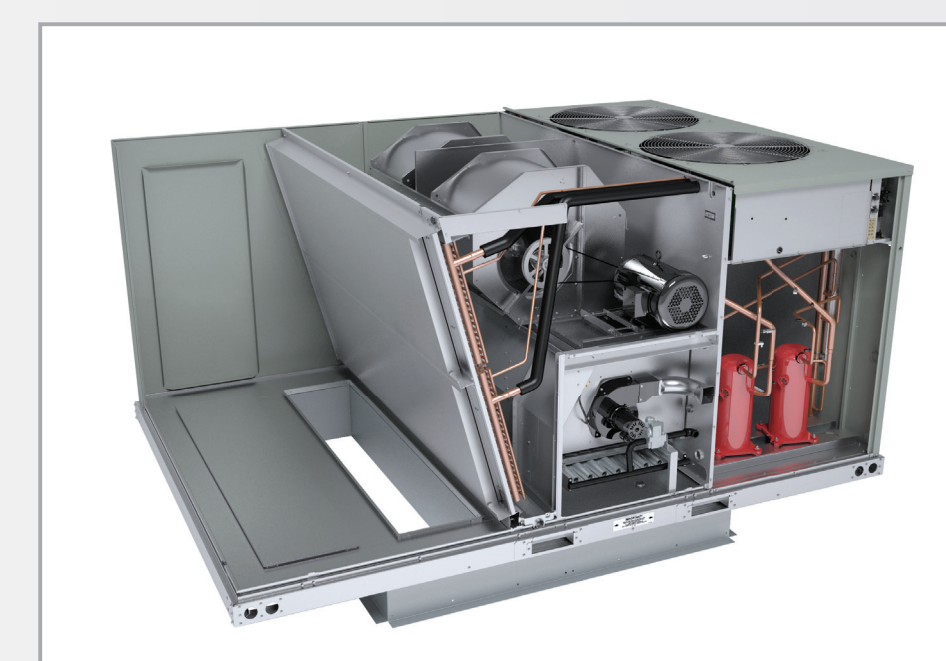
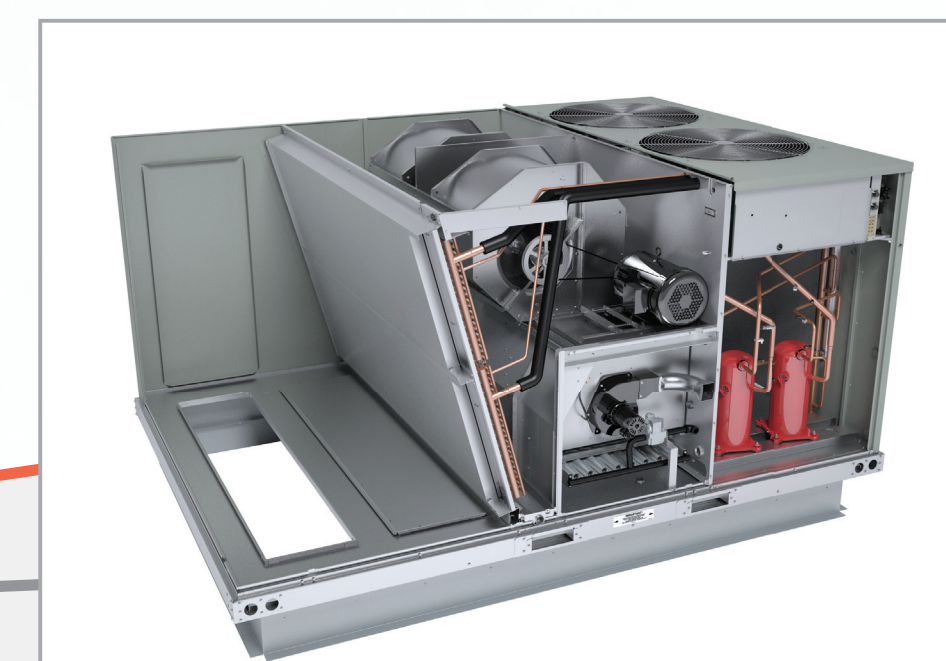

Unique dual-footprint design allows compatibility with multiple roof curbs — without expensive adapters or other modifications.



Scan the code or visit Trane.com/Foundation to learn more.



Trane belongs to Ingersoll Rand's family of brands, including Club Car®, Ingersoll Rand®, Schlage® and Thermo King®. Ingersoll Rand is a world leader in creating and sustaining safe, comfortable and efficient environments. © 2013 Ingersoll Rand





Scan the code or visit
Trane.com/Foundation
to learn more.

BIM
Ready



Trane[®] Foundation[™] light-commercial rooftop units

**Every successful building needs
a strong foundation.**

An HVAC solution with solid benefits.

- Proven performance from field-tested components
- Simple design shaped by input from rooftop unit owners and users
- Actively managed manufacturing and inventory for fast shipping

Key features

- Long-life compressor and heat exchanger
- High-strength bolted frame
- Easy-access service panels

Unique dual-footprint design
allows compatibility with multiple roof curbs —
without expensive adapters or other modifications.

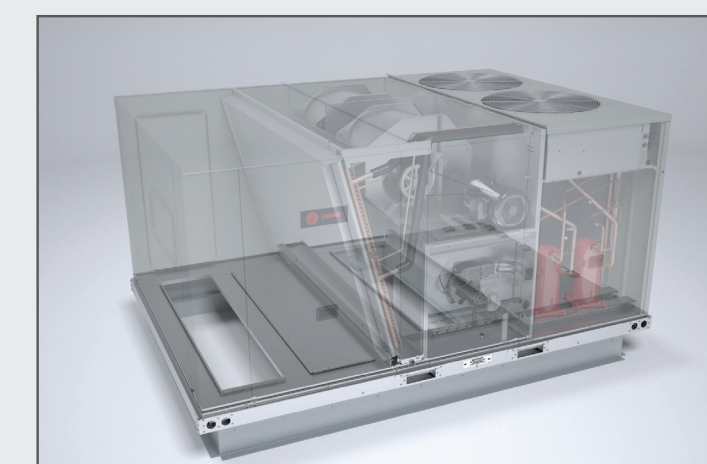

**Trane
roof curb**

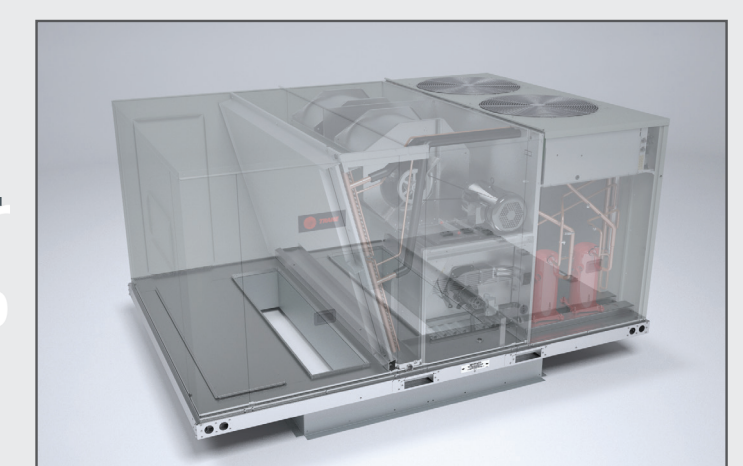

**Other
roof curb**

Trane belongs to Ingersoll Rand's family of brands, including Club Car[®], Ingersoll Rand[®], Schlage[®] and Thermo King[®]. Ingersoll Rand is a world leader in creating and sustaining safe, comfortable and efficient environments.

© 2013 Ingersoll Rand

